

RoHS2.0
Compliant

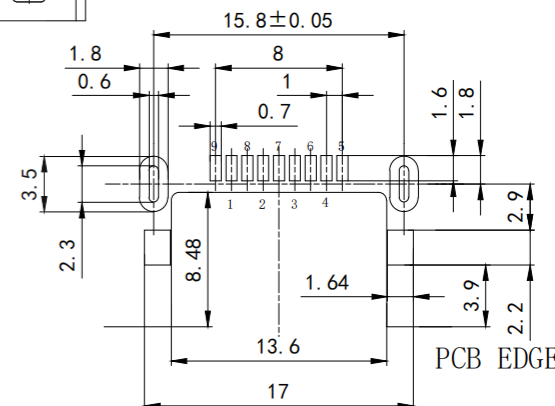
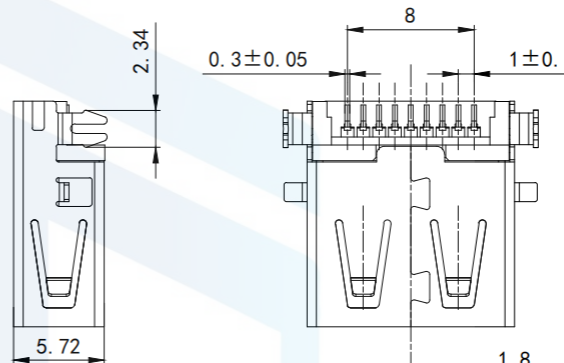
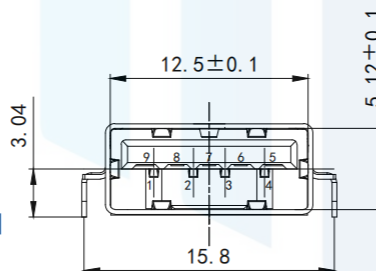
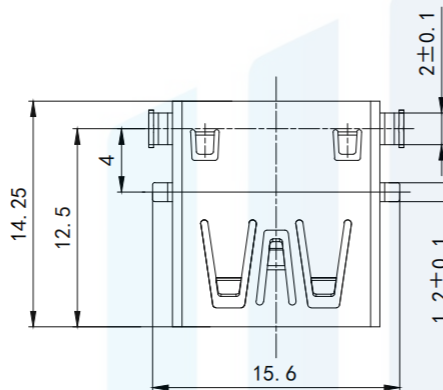
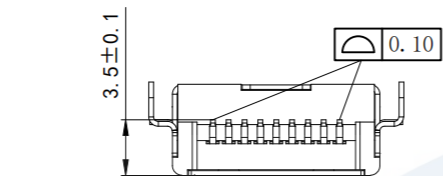

Pin NUMBER	SIGNAL NAME
1	VBUS
2	D-
3	D+
4	GND
5	StdA_SSRX-
6	StdA_SSRX+
7	GND_DRAIN
8	StdA_SSTX-
9	StdA_SSTX+
Shell	Shield

NOTE:

1. MATERIAL:

- 1.1 INSULATOR:LCP UL 94V-0
- 1.2 CONTACT:BRONZE (T=0.20mm)
- 1.3 SHELL:SUS201 (T=0.30mm)

2. ELECTRICAL CHARACTERISTICS;

- 2.1 CONTACTRESISTANCE:30mΩ MAXIMUM
- 2.2 CONTACT CURRENT RATING:1.5A
- 2.3 DIELECTRIC WITHSTANDING VOLTAGE:500 V

R. M. S.

- 2.4 INSULATION RESISTANCE 1000 MEGOHMS MIN
- 2.5 OPERATING TEMPERATURE:-40° C ~ 85° C

3 MECHANICAL CHARACTERISTICS:

- 3.1 MATING FORCE:3.57kg MAX
- 3.2 UNMATED FORCE:1.02kg MIN
- 3.3 DURABILITY:MANDATORY:5,000 CYCLES

4. PLATING

4.1 TERMINAL:

50u" MIN NICKEL ALL OVER
100u"MIN Tin ON SOLDER AREA
(1~30)u"Au ON CONTACT AREA

4.2 SHELL:100u"MIN. NICEL ALL OVER

TOLERANCE

X. XXX	±0.05
X. XX	±0.15
X. X	±0.20
X.	±0.30
ANGLE	±5.0°

PROTECTON

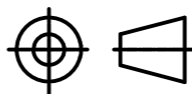

东莞市恒祺电子科技有限公司

Dongguan Hengqi Electronic Technology Co., Ltd

<https://www.hq-dz.com>

phone:15812872448

TITLE:

USB3.0 A/F 沉板贴片H=3.5直边
定位脚鱼叉脚

PART NO:USB3.0-V104

DRAWING NO:14.25*15.6*5.72

DRAWN:

CHECKED:

APPROVED:

DATE:

DATE:

DATE:

18-10-08

18-10-08

18-10-08

UNIT:
mm

SCALE:
FULL

SIZE:
A4