

RoHS2.0
Compliant

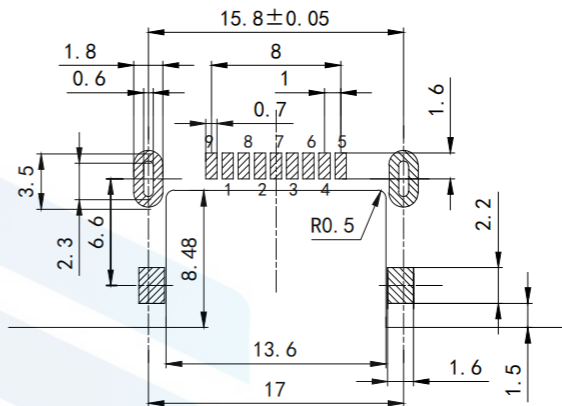
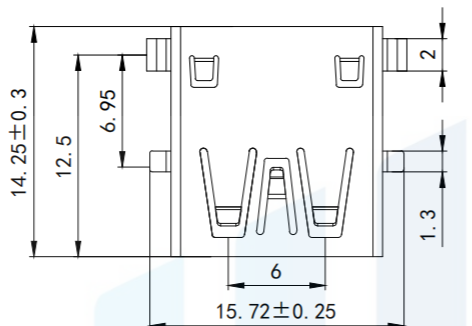

Pin NUMBER	SIGNAL NAME
1	VBUS
2	D-
3	D+
4	GND
5	StdA_SSRX-
6	StdA_SSRX+
7	GND_DRAIN
8	StdA_SSTX-
9	StdA_SSTX+
Shell	Shield

NOTE:

1. MATERIAL:

- 1.1 INSULATOR: LCP+30%GF, UL94V-0,
- 1.2 CONTACT 1~4PIN: C5191R/H
- 1.3 CONTACT 5~9PIN: C5191R/H
- 1.4 SHELL: SUS201 T=0.3

2. PLATING:

- 2.1 CONTACT: SELECTIVE GOLD PLATED ON CONTACT AREA
100u" Min. MATTE TIN PLATED ON SOLDER TAIL

- 2.2 SHELL: 50u" Min. NICKEL UNDER-PLATED
50u" Min. NICKEL PLATED OVERALL

3. CHARACTERISTICS:

- 3.1 ELECTRICAL CHARACTERISTICS:
CONTACT RESISTANCE: 30mΩ MAXIMUM
CONTACT CURRENT RATING: 1.5A
DIELECTRIC WITHSTANDING VOLTAGE: 500 V
- R. M. S.
INSULATION RESISTANCE 1000 MEGOHMS
- MIN
OPERATING TEMPERATURE: -25°C ~ +85°C

3.2 MECHANICAL:

- MATING FORCE: 3.57Kg. Max.
- UNMATING FORCE: 1.02Kg. Min.
- 4. DESIGN STANDARD ACCORDING TO USB_3.0

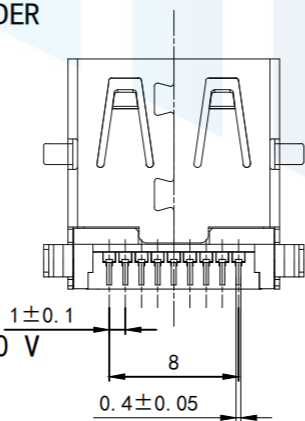
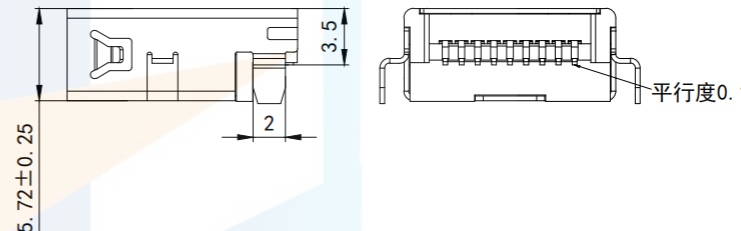
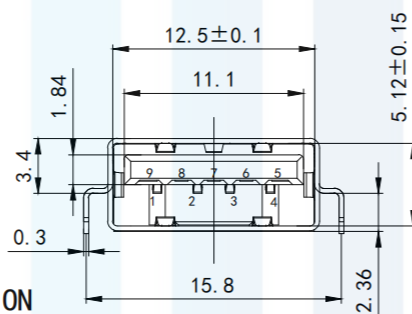

TOLERANCE

X. XXX	±0.05
X. XX	±0.15
X. X	±0.20
X.	±0.30
ANGLE	±5.0°

PROTECTON

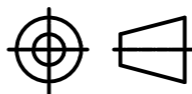

东莞市恒祺电子科技有限公司
Dongguan Hengqi Electronic Technology Co., Ltd

<https://www.hq-dz.com>

phone: 15812872448

TITLE:

USB 3.0 A/F 沉板H3.5贴片直边
4脚定位外移前贴后插

PART NO: USB3.0-V210

DRAWING NO: 14.25*15.72*5.12

DRAWN:

DATE:

18-10-08

UNIT:
mm

CHECKED:

DATE:

18-10-08

SCALE:
FULL

APPROVED:

DATE:

18-10-08

SIZE:
A4

SPECIFICATION.